

TP040

Tube/Tube Sheet Orbital Weld Head

Summary

This weld head is special designed automatic TIG orbital welding for tube/tube sheet. It's suit for CS, SS tube/tube sheet flush welding without wire feeding to achieve ideal repeatable welding quality. It's compatible with iOrbital4000, iOrbital5000 programmable digital welding power source and apply in chemical, food, medicine, heat exchanger, power plant, military, nuclear etc.

Features

- Widely used in power plant/condenser stainless steel/titanium alloy tube to tube-sheet welding;
- Without wire feeding, small size and light, easy for operation;
- Expandable collet positioning design, precise position;
- Closed welding achieving perfect welding quality;
- No wire winding twisting, enhanced water cooling system, high duty cycle for long time using.

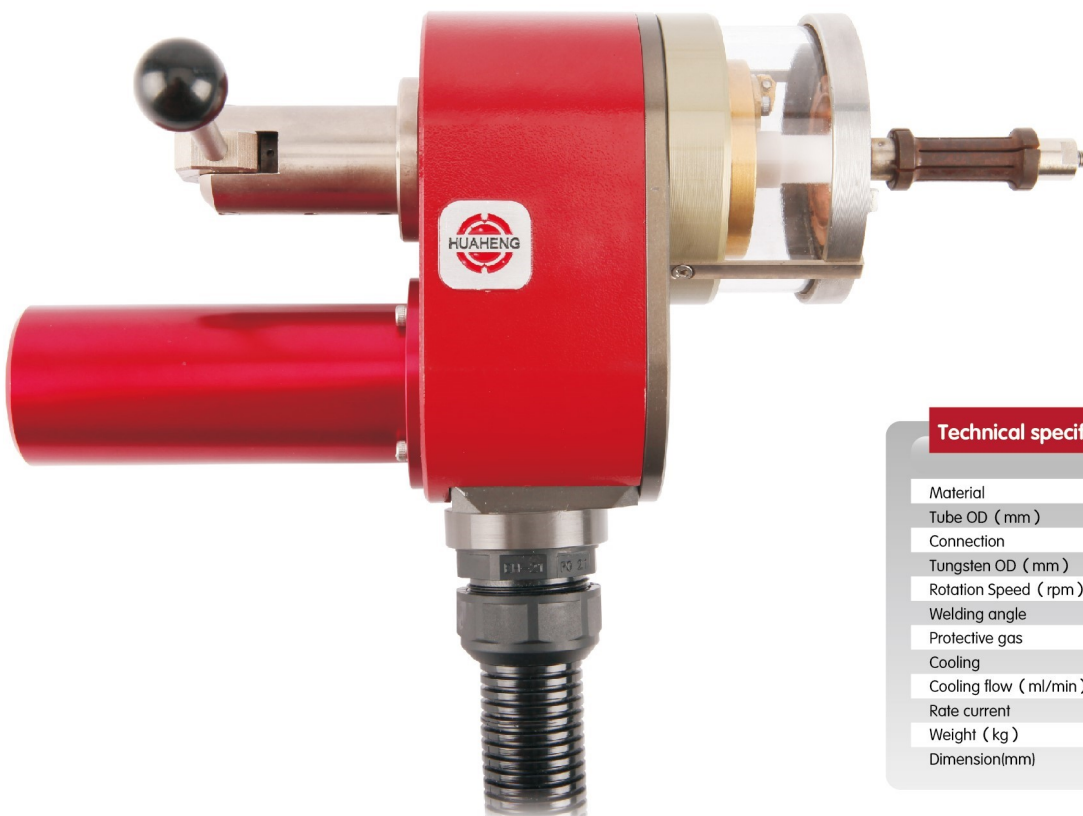
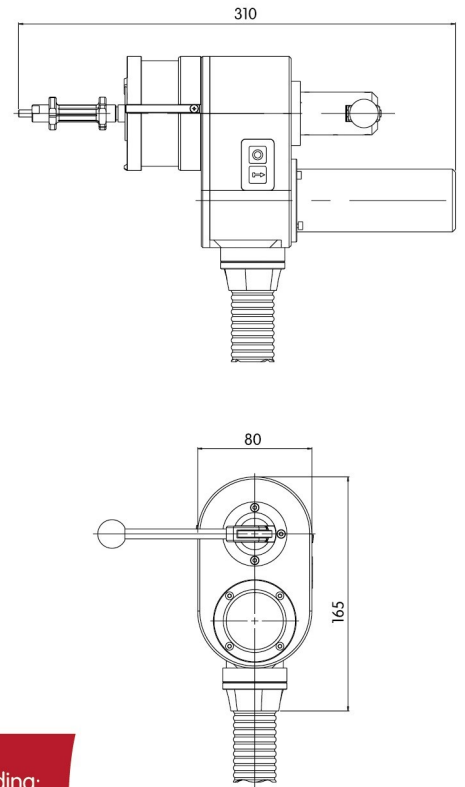

Technical specification

Material	Carbon steel, stainless steel, titanium alloy
Tube OD (mm)	Φ16-Φ38 (5/8"-1 1/2")
Connection	Flush tube
Tungsten OD (mm)	Φ2.4
Rotation Speed (rpm)	0.6-12
Welding angle	0°、7° option (standard 7°)
Protective gas	Ar
Cooling	Water
Cooling flow (ml/min)	≥300
Rate current	100A 60%
Weight (kg)	3.65(no cable)
Dimension(mm)	310 × 80 × 165